

DTS-200

Digital Broadcast Field Test Tool



Key Features

- Access MPEG-2 streams at traditional, RF, or data test points, and test both the MPEG and carrier signals.
- Operate from the office, lab, home, or locally in stand-alone mode.
- Perform real-time analysis and monitoring to verify stream contents, service plans, PIDs, rates, timing parameters, and ETR-290.
- Generate event logs, triggers, and reports for baselining and comprehensive monitoring.
- Identify problems and collect evidence of faulty equipment or content to maximize response and resolution from vendors and providers.
- JDSU Advantage services, such as an MPEG-2 training course in a choice of formats, are available locally providing you with product life cycle support.

Network operators are rapidly migrating to digital networks to provide premium audio, video, and data services. This move is accompanied by an increase in the volume and complexity of broadcast equipment and by the use of MPEG-2, the worldwide standard for carrying broadcast-quality compressed digital video, audio, and data signals. The quality of digital services is primarily dependent upon the hardware, systems, and networks used to create, manage, and deliver the programming. Therefore, to fully realize digital broadcasting's promise of increased revenue and service-delivery opportunities, network operators and broadcasters must continually test and monitor both the network equipment and the MPEG-2 digital signals.

The JDSU DTS-200 is a compact, scalable test platform designed to meet the needs of digital network operators, field support teams, and equipment manufacturers. Capable of capturing and playing MPEG-2 transport streams as well as performing complete real-time monitoring and analysis of these streams, it allows operators to gain visibility into the digital traffic, identify problems with equipment or content, and minimize downtime. Additionally, the DTS-200 analyzes various physical or data signals used to carry the MPEG-2 traffic, making it a true one-box solution.

Supporting your DTS-200 purchase at no extra cost, our Technical Assistance Center (TAC) is available to answer all your product questions. To enhance your investment and complement the solution, we offer a full portfolio of JDSU Advantage services. These include education programs, extended warranties, calibration, and Service ValuePak for Instruments, an economical bundled package of product support services.

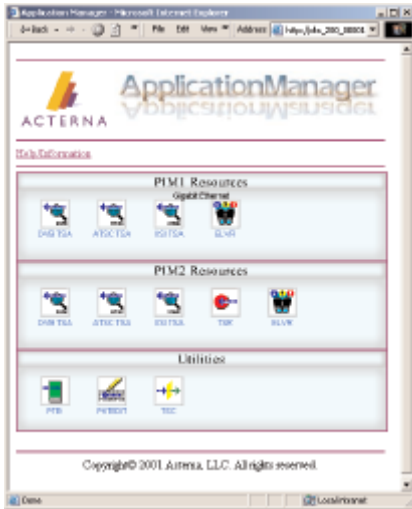

DTS-200 Application Manager

Product Features

Maximize engineering resources with remote operation

Although there is an army of technicians and engineers who know traditional RF broadcast technology, very few have experience with digital technologies such as MPEG, DVB, and ATSC. And those who are knowledgeable are spread thinly among an operator's development, provisioning, and maintenance teams. Given the scale of digital deployments and relative youth of the technology, this lack of knowledgeable resources can delay and cause problems when operators roll out digital networks.

JDSU introduced the DTS-200 to provide broadcasters with a portable solution that helps to eliminate many of these bottlenecks. Users with minimal training easily access and operate the DTS-200 remotely over 10/100 Ethernet from one or more networked client machines located in the office, lab, or home. This capability maximizes operators' engineering resources and helps cut back on travel costs. The DTS-200 is easily transported in the field and can operate in stand-alone mode when a client machine is not available.

Upgrade with multiple interfaces to test MPEG-2

With the DTS-200, JDSU continues its long tradition of providing advanced digital broadcast test instruments designed with intuitive, easy-to-use features and powerful automated functions. Client software is downloaded over the network connection, eliminating the need to install software manually, which means that once the DTS-200 is out of the box and put on the network, it can be reached by a client machine instantly.

Although digital networks employ a variety of transmission methods, an MPEG-2 transport stream is at the heart of each. To accommodate the horizontal nature of the digital broadcast market, the DTS-200 embraces a modular design that allows users to easily interchange plug-in modules (PIMs) for various input and output interfaces used to carry MPEG-2 streams. These include standard digital interfaces that range from DVB ASI, DVB SPI, and SMPTE-310M to QAM; QPSK RF interfaces; and a Gigabit Ethernet data interface. This modularity provides users with a cost-effective and flexible platform that enables them to upgrade their DTS-200 without purchasing new instruments and software as configuration needs are defined and expanded. By inserting a new module with the appropriate built-in software interface, the DTS-200 is automatically upgraded to operate with new services and technologies.

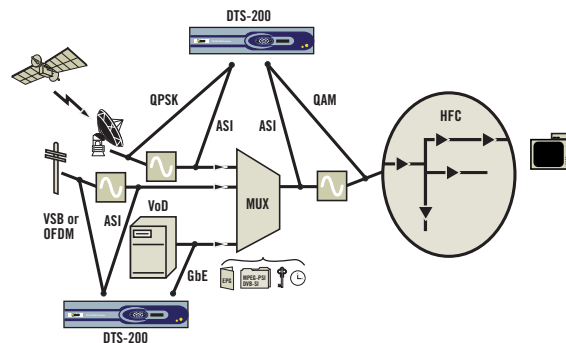

Figure 1 DTS-200 with mux



Summary View



PID Watch/Rate History Chart

The DTS-200's software applications are easily activated through centrally located tool buttons. And its clear, easy-to-interpret displays enable users, even those who are less experienced, to become familiar with the structure and content of an MPEG-2 transport stream and quickly verify the status of the stream and troubleshoot on the fly.

Perform real-time analysis and monitoring

The MPEG-2 transport stream is highly complex and transports real-time data via high bit rate mechanisms. These upstream errors, without correction, can propagate to drastic magnitude. To prevent this, operators need to have visibility into and analysis of the MPEG-2 transport layer.

The DTS-200's comprehensive and powerful analyzer supports data rates up to 214 Mbps and tracks over 200 events and errors. The analyzer interface has several top-level views that summarize transport stream contents and statistics and allow quick drill down into detailed measurements for rapid and complete diagnostics. All events that have occurred on the stream relative to any one of the measured parameters and graphical displays of PCR/PTS timing and historical or instantaneous rate calculations are available.

Through the DTS-200's sleek, easy-to-use interface, and with a single click of the mouse, users have instant access to over a dozen main displays including:

- Summary view
- PID information view
- PID watch view
- ETR-290 monitoring view
- PSI/SI/PSIP table hierarchical view
- Timing view
- Program/channel view
- CA hierarchical view
- Private table hierarchical view
- Network view (DVB)
- MPE IP view (DVB)
- Terrestrial MIP view (DVB)
- OpenTV carousel hierarchical view

Applications

Identify faulty equipment and content errors for swift problem resolution

Digital transmission systems almost always rely on equipment made by multiple manufacturers. A multiplexer from one company, for instance, must be able to read the output of another manufacturer's encoder. When systems are not interoperable, broadcasters often shoulder the blame for network failures. As a result, they bear the expense of isolating problems and finding solutions from manufacturers, in addition to suffering the loss of revenue from customer turnover, credits, and penalties.

The DTS-200's analyzer rapidly identifies and isolates problems. In addition, it records sections of the transport stream, allowing users to reproduce a problem, which is a valuable tool for troubleshooting MPEG problems that are both sporadic and spurious in nature. Stream captures provide a key form of evidence that a problem exists and help broadcasters determine if the problem lies with the equipment or with the content. This capability significantly reduces finger pointing between manufacturers and content providers.

Provision equipment and networks and baseline performance

When network operators provision equipment and networks, the DTS-200 offers multiple advantages. In addition to sourcing known streams (good or bad) into the broadcast equipment, it also can simultaneously analyze the MPEG-2 stream at the output of that equipment, or anywhere else downstream, and generate specific reports and event logs on virtually any parameter.

The DTS-200's report function can be triggered manually or by any of over 200 events, allowing the user to take a "snapshot" of the stream status. The user can specify what is entered in the report and can include virtually any parameter or measurement the analyzer supports.

Assess transport stream contents and status rapidly

When working on a stream, operators need to know what is on it. The DTS-200's analyzer will break down the entire stream, including items it cannot recognize, indicate the PIDs (ID info) for all items, and indicate the rate and bandwidth percentages. Further, it provides a real-time display of the ETR-290 performance. ETR-290 has three categories of MPEG/DVB errors, ordered by severity. The analyzer will track these errors, keeping a running total with events logs for each error that has occurred. Through the PID info view and the ETR-290 view, a user can immediately assess the contents and health of an MPEG-2 stream. More detailed troubleshooting can be performed using the event logs and one of the many other views in the analyzer.

MPEG-2, DVB and ATSC training

JDSU offers a seminar on digital broadcast basics, which includes instruction on how to test MPEG-2/DVB systems, that is available locally as an instructor-led course in one of JDSU's training centers around the globe or at your facility. Also available via JDSU's new E-Learning Virtual Classroom, this seminar is a cost-effective way for companies with budget and travel constraints to provide training to employees scattered across a large geographic area.

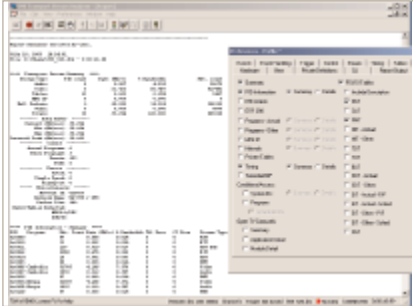

Report Screen

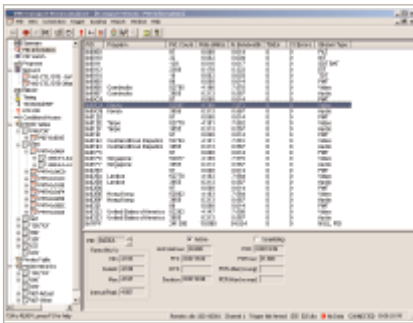

PID Information View

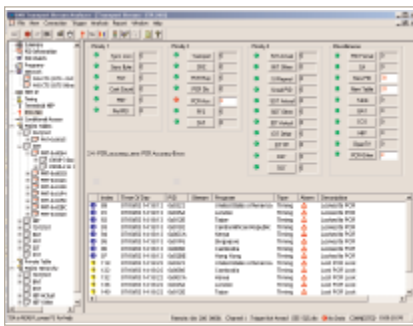

ETR-290 View

5

Specifications

System Specifications

The DTS-200 system is a self-contained unit designed for operation over a network connection. It is based on the Microsoft Windows NT Platform, has an 80 GB disk drive, and an Ethernet interface (10/100 BaseT). There are also standard peripheral ports for operation as a stand-alone machine.

Peripherals

VGA display, mouse, and keyboard

Dimension

Width	39.5 cm
Height	11 cm
Length	27.5 cm
Weight	15.4 lbs/7 kg

Digital Transport Plug-In Module Interfaces

(ASI and SPI interfaces support 188-, 204-, & 208-byte packets)

DVB ASI	75 ohm BNC
DVB SPI (LVDS)	DB25
SMPTE-310M	BNC

System Clock

Internal Clock	27 MHz
Internal Clock Accuracy	5 ppm
Internal Clock Stability	1 ppm/year
Internal Clock Resolution	1 Hz
Output Clock (SPI)	1 kHz to 15 MHz
Input clock	up to 15 MHz

Electromagnetic Compatibility (EMC)

CE	EN 50081-1, EN 50082-1
FCC	Part 15, Sub Part B, Class A
Safety	IEC 1010, EN 61010
MPEG-2 ISO/IEC Protocols	13818-1/-2/-3/-4/-9
ATSC Protocols	A/52, A/53, A/65
DVB Protocols	ETS 300 468, ETS 211, ETR154/162/290, PrEN 50083-9, TS 101191

Maximum Data Rate

Real-time Analysis/Stream Creation	214 Mbps
Recording/Playback (to disk)	90 Mbps
Recording/Playback (to memory)	214 Mbps

Maximum File Size

Circular Capture Buffer	128 MB
High-speed Mode	128 MB
Disk	disk capacity

Ordering Information

The following DTS-200 packages include the DTS-200 chassis, one or more Plug-In Modules (PIMs), cables, and user manuals. Please contact your local sales representative to order these packages, or any of several individual DTS-200 items not listed here.

Part and Description

7553/20	DTS-200 with 1 PIM - Analyzer-Standard
7553/30	DTS-200 with 1 PIM - Analyzer-Advanced
7553/21	DTS-200 with 1 PIM - Analyzer-Std/Record
7553/31	DTS-200 with 1 PIM - Analyzer-Adv/Record
7553/23	DTS-200 with 2 PIMs Analyzer-Std/Generator
7553/33	DTS-200 with 2 PIMs - Analyzer-Adv/Generator
7553/01	DTS-200 with 1 PIM - Record
7553/02	DTS-200 with 1 PIM - Play
7553/03	DTS-200 with 2 PIMs - Generator